



REACTOR® 3

Graco's top of the line electric reactors for spray foam and polyurea applications.



PROVEN QUALITY. LEADING TECHNOLOGY.

AEMCO

+966 -11- 21 40 888
marketing@aemco-llc.com
www.aemco-llc.com

جده الدمام الرياض
Riyadh Dammam Jeddah



Genuine People
Genuine Spares
Genuine Service

THERE IS NOTHING LIKE A GRACO ELECTRIC REACTOR

Experienced contractors know the difference. Graco's range of professional electric Reactors for spray foam and polyurea applications are solid investments that perform reliably, year after year.



Automated on-ratio performance

In the Reactor 3 system all components from drum to gun can be fully connected. The Graco electric Reactor 3 communicates with all components for perfect ratio control, material supply, temperature control... which guarantees best performance while reducing the risk of suboptimal results or health risks.



Faster, lighter & easier

The Reactor 3 system is a dream to work with. You get more work done with less effort. The touchscreen means easy operation and monitoring. You can easily move the entire rig around to where you need it, thanks to the reduced reactor weight, size and power requirements.



Optimised productivity and profitability

Using the Reactor 3 allows you to optimise productivity and get a consistent high yield with less excess waste. Enjoy lower start-up costs thanks to a smaller generator, compressor and rig. Remote control and monitoring, quick pump changeovers and less downtime on the job mean you enjoy a substantial productivity increase.



GRACO-ONLY SOLUTIONS THAT KEEP YOU SPRAYING



THE ONLY FULLY CONNECTED DRUM-TO-GUN SYSTEM

- Maximize your benefits and protection with application intelligence
- Allows first-time sprayers to achieve professional results
- Intelligence to stay on-ratio and improve yield



MAXIMIZE PRODUCTIVITY WITH REMOTE CONTROL AND MONITORING

- Remotely control your machine with the Reactor Connect app
- Easy monitoring and troubleshooting with real-time fleet dashboards
- Streamline your business with job reports and data analytics



QUICK CHANGE-OVERS TO FINISH JOBS FASTER

- Quickly switch your pump between drums
- Easily move your pump in low ceiling height rigs
- Makes pump rebuilds fast and easy



EXCLUSIVE ELECTRIC TRANSFER PUMP TECHNOLOGY

- Communicates with the Reactor for improved ratio assurance and yield
- Automatically shuts down when you run out of material
- Monitors inlet pressures and self-adjusts to optimize material feed
- Quiet operation



STRONGER, FASTER TO HEAT, LIGHTER HEATED HOSE DESIGN

- Independent A and B temperature control for improved pressure balancing and yield
- Longer life and improved reliability with new robust hose construction
- Internally or externally heated options to meet all your needs



NO MATTER WHAT THE APPLICATION, GRACO HAS THE SOLUTION

Whether you're spraying foam or applying polyurea coatings, Graco Reactor3® will help you get the job done! Graco's Reactor 3 range can be used from small residential insulation jobs to waterproofing large decks. Available in Standard, Pro or Elite series, we have the right equipment to meet your needs.

Standard Series: Everyday reliability and simple operation for rough environments or startup businesses

Pro Series: Improve spray results, limit maintenance and track your performance to finish more and bigger projects

Elite Series: Fully expand & monitor your own or your teams' spray capabilities, protect the chemical ratio and improve yield to benefit your company's performance and to save time.

Reactor 3 is not just a new proportioner. Graco has developed a fully new platform that can be connected from Drum-to-Gun. Next to the new proportioner, Graco has developed new internally and externally heated hoses (Xcelerator), new pneumatic (T4) or electric feed pumps (Core) that incorporate pro-connect technology and that are able to communicate to the Reactor proportioner. The Reactor 3 line is modular and allows you to choose & combine the correct series of Reactor, the type & length of heated hoses and the feeding system (electric/pneumatic) that best serve your business - & application needs.

The top of the range – the fully connected Graco Reactor 3 Elite with internally heated hoses and Core electric feed pumps is the world's most advanced spray foam/polyurea system. With connectivity from drum-to-gun, you can precisely control heat, pressure and flow.



CORE NEW CORE E1 PATENT PENDING TRANSFER PUMPS

Designed to optimize material supplied and minimize downtime. Quieter than your typical pneumatic pumps, while also able to communicate with the Reactor 3 to create a fully-connected system.

Picture shown represents an Elite model system

Standard and Pro models can upgrade hardware to activate Katalyst System Intelligence.

Reactor 3 NEW REACTOR 3 ELECTRIC PROPORTIONER PATENT PENDING

The Reactor 3 Electric Proportioner is easy to operate & maintain and runs quick & efficient. Pick your series; from simple straightforward Standard units to Elite units that are able to communicate with the entire system to improve performance and yield.

Reactor Connect REACTOR CONNECT PATENTED

Control your system with Reactor Connect and be more productive. Access your Reactor right from the gun. Monitor and adjust your proportioner and keep right on spraying. No hassles. That means you can get more done in your day, with less downtime and with reports and proof of your quality work!

Xcelerator NEW XCELERATOR HEATED HOSE PATENT PENDING

Xcelerator internally or externally heated hoses are independently temperature controlled. The internally heated hoses have 40% faster warm-up times and are 10% lighter than the traditional externally heated hose. Hoses are now available in 15m and 30m length sections to minimize weight and fluid connections.

THE ONLY FULLY CONNECTED SYSTEM FROM DRUM-TO-GUN

Reactor 3 Elite model with Core E1 Transfer Pumps are necessary to activate Katalyst System Intelligence.

FOR MORE INFORMATION, VISIT GRACO.COM/REACTOR3

WHICH SYSTEM IS RIGHT FOR YOU?

Easy to Upgrade. Add Elite Features Later as Your Business Grows

Purchase the Reactor 3 system that makes sense for your business now and add features along the way. The Reactor 3 line allows you to start with a Standard or Pro and upgrade to Elite capabilities at any time.

CHOOSE THE REACTOR 3 MODEL THAT BEST FITS YOU



Standard



Pro



Elite

- Touch Screen ADM
- Brushless Motor
- Active ISO Lube Pump
- Data Download (with USB)
- Small Recirculation Valves
- Simple Y-strainers
- Software:**
 - Independent A & B Hose Heat
 - Resistance Control Mode



All the features of Standard PLUS...

- Larger Heater Options
- Large Easy Access Inlet Filters
- Reactor Connect Cell Module
- Large Recirculation Valves
- Drum Level Dipsticks

- Software:**
- Auto Pressure Balance
 - Power Management
 - Automatic Cellular Software Updates



All the features of Pro PLUS...

- Katalyst Full System Control
- Ratio Assurance
- Inlet Temperature & Pressure Sensors
- Generator Dashboard
- Optimized for Core E1 Transfer Pumps

- Software:**
- Smart Control
 - Smart Supply

SELECT YOUR PERFORMANCE LEVEL

Every Business Need is Different

Reactor 3 has a performance point to meet every business need. Whether you are just starting your business and want a reliable machine at a reasonable price or are an established business looking to expand your capabilities and improve your productivity, we have a machine that will meet your needs.

CHOOSE AN OPTION THAT MEETS YOUR NEEDS

SPRAY FOAM OPTIONS

PROPORTIONER	STANDARD		PRO		ELITE	
MODEL	E-20	E-30	E-20	E-30	E-20	E-30
MOTOR	1.8 HP Brushless	2.5 HP Brushless	1.8 HP Brushless	2.5 HP Brushless	1.8 HP Brushless	2.5 HP Brushless
MAX FLOW	9 kg (20 lb)/min	13.6 kg (30 lb)/min	9 kg (20 lb)/min	13.6 kg (30 lb)/min	9 kg (20 lb)/min	13.6 kg (30 lb)/min
MAX PRESSURE	140 bar (2000 psi)	140 bar (2000 psi)	140 bar (2000 psi)	140 bar (2000 psi)	140 bar (2000 psi)	140 bar (2000 psi)
PRIMARY HEAT	7 kW Sngl. Block	10 kW Sngl. Block	7 kW Sngl. Block	10 kW Sngl. Block	10 kW Sngl. Block	15 kW Dual Block
MAX HOSE LENGTH	67m	97m	67m	97m	67m	97m

POLYUREA OPTIONS

PROPORTIONER	STANDARD		PRO		ELITE	
MODEL	E-XP1	E-XP2	E-XP1	E-XP2	E-XP1	E-XP2
MOTOR	1.8 HP Brushless	2.5 HP Brushless	1.8 HP Brushless	2.5 HP Brushless	1.8 HP Brushless	2.5 HP Brushless
MAX FLOW	5.7 L (1.5 gal)/min	7.6 L (2 gal)/min	5.7 L (1.5 gal)/min	7.6 L (2 gal)/min	5.7 L (1.5 gal)/min	7.6 L (2 gal)/min
MAX PRESSURE	206 bar (3000 psi)	240 bar (3500 psi)	206 bar (3000 psi)	240 bar (3500 psi)	206 bar (3000 psi)	240 bar (3500 psi)
PRIMARY HEAT	10 kW Sngl. Block	15 kW Dual Block	10 kW Sngl. Block	15 kW Dual Block	10 kW Sngl. Block	15 kW Dual Block
MAX HOSE LENGTH	67m	97m	67m	97m	67m	97m

WHAT'S INCLUDED IN EACH PACKAGE:

PACKAGE OPTIONS	STANDARD	PRO	ELITE
EXTERNALLY HEATED HOSE (EH) PACKAGES AVAILABLE	Yes	Yes	Yes
INTERNALLY HEATED HOSE (IH) PACKAGES AVAILABLE	Yes	Yes	Yes
WHIP HOSE LENGTH INCLUDED IN PACKAGES	3m Whip in EH packages, 6m Whip in IH packages	3m Whip in EH packages, 6m Whip in IH packages	6m Whip
ITEMS INCLUDED IN SINGLE HOSE PACKAGE	Reactor, Whip Hose, 1 - 15m Hose	Reactor, Whip Hose, 1 - 15m Hose	Reactor, Whip Hose, 1 - 15m Hose, Eng. CAN Cable
ITEMS INCLUDED IN MULTI-HOSE PACKAGE	Reactor, Whip Hose, 2 - 30m Hoses	Reactor, Whip Hose, 2 - 30m Hoses	Reactor, Whip Hose, 2 - 30m Hoses, Eng. CAN Cable

SPRAY FOAM FLOW CHART

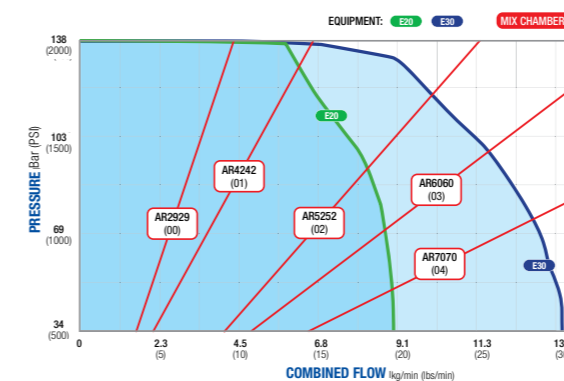

POLYUREA FLOW CHART

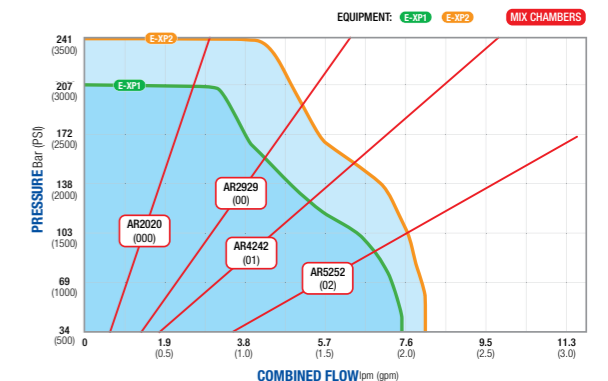

REACTOR 3 ELECTRIC PROPORTIONER

Spray with confidence

Upgrade your rig with a powerful NEW Reactor 3 proportioner, built with advanced capabilities for spray foam and polyurea applications. Reactor 3 is designed to simplify the operators job, optimize spray parameters and maximize productivity.

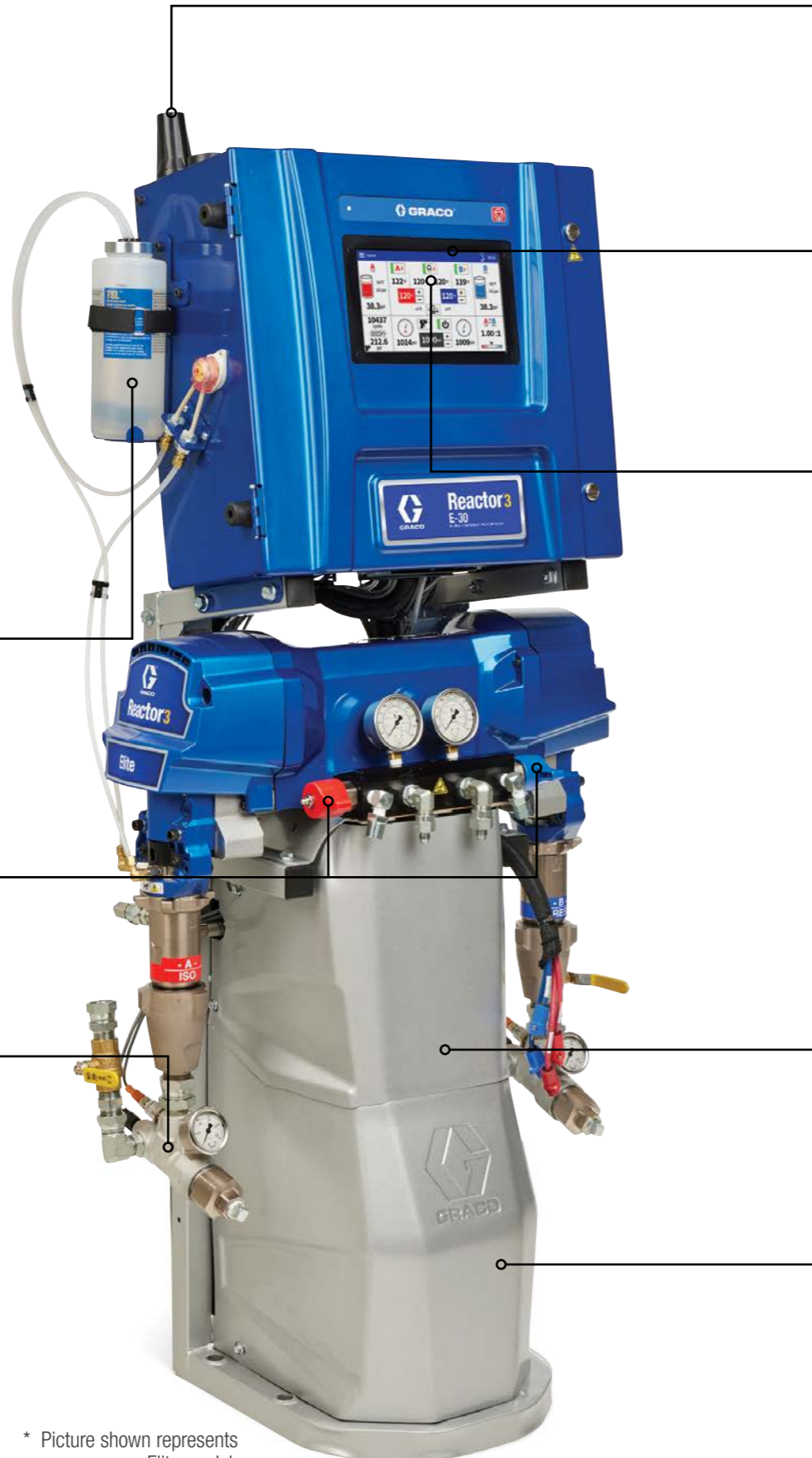

NEW ISO LUBE PUMP

- Active ISO Lube system with peristaltic pump
- Automatic timed circulation improves TSL Life
- Reduced maintenance (No check valves)
- New larger easy-to-change ISO lube bottle

NEW FLUID MANIFOLD

(Pro and Elite Series only)

- Redesigned with side-mounted fluid valves for easier turning and improved control

NEW INLET FILTERS

(Pro and Elite Series only)

- New easy-to-maintain design
- 2X larger filter area
- Separate temperature and pressure sensors for more accurate temperature readings (Elite Series only)

REACTOR CONNECT

(Pro and Elite Series only)

- Real-time dashboard and reports via cellular connectivity
- Improved cellular antenna
- New GPS antenna
- GPS location available in Reactor Connect

NEW TOUCHSCREEN ADVANCED DISPLAY MODULE (ADM)

- Large new touchscreen interface
- Intuitive operation and navigation
- All spray operations from one screen

NEW INDEPENDENT HOSE CONTROL

- Control A and B materials to different temperatures for improved pressure balancing
- Optimizes yield

NEW ADVANCED ELECTRIC DESIGN

- Brushless motor for improved pressure/flow performance
- New Temperature Control boards for independent hose heat
- Voltage jumpers for easy changing between voltages
- Robust UL listed electrical hose connectors are color coded and keyed for error proof assembly
- New Reactor 3 exclusive: connect with Tier 4 engines for ADM engine diagnostic (Elite Series only)

OVAL GEAR FLOW METERS (under shroud)

(Elite Series only)

- Verifies fluid ratio
- Provides real-time ratio data: displayed on the ADM and Reactor Connect
- Accurate for a wide range of fluid viscosities

REDUCED SIZE

- Reduced footprint provides additional room in your rig
- Compact design protects the flow meters and hose connection from being damaged in your rig

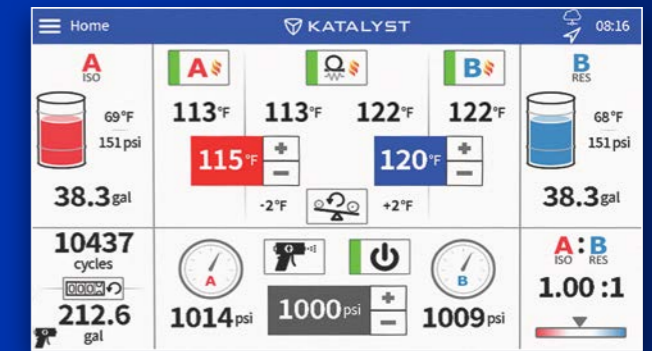

NEW ADVANCED SOFTWARE FEATURES

- **Katalyst:** Reactor Intelligence from drum-to-gun. System communication and control that improves performance, ratio and yield. (Requires Elite Reactor paired with Core E1 pumps)
- **Auto Pressure Balance:** Reactor automatically adjusts temperatures to optimize fluid pressures and maximize yield. (Pro and Elite Series only)
- **Supply Pump Shutdown:** Automatically shuts down when you run out of material. Prevents air from entering the system that can cause off-ratio issues. (Requires Core E1 pumps)
- **Smart Supply:** Automatically monitors and adjusts fluid inlet pressures to compensate for high viscosity (e.g., cold) materials to keep you spraying on ratio. (Requires Elite Reactor paired with Core E1 pumps)
- **Smart Control:** software that monitors inlet pressure and makes adjustments to the motor speed of the Reactor to attempt to prevent off-ratio dispensing. Especially in scenarios of high volume output and small pneumatic feed pumps. (Elite Series only)
- **Resistance Control Mode:** Accurately monitors and controls hose temperatures without the hassles of fluid sensors and RTD cables.
- **Power Management:** Select desired heater wattage for reduced power consumption. (Pro and Elite Series only)
- **Cellular Software Updates:** Automatically stay up to date with the latest Reactor software. (Requires Reactor Connect) (Pro and Elite Series only)
- **Jog Countdown Timer:** Input a cycle count value and have the machine run and shut off after that exact value to assist in precisely flushing the system

* Picture shown represents an Elite model.

* Hardware and software kits are available to upgrade a Standard model to Pro or Elite

NEW TOUCHSCREEN CONTROL

Easier to Control and Access Information

The new larger interface provides simple touchscreen operations and makes the Reactor easy to operate. All the necessary spray information and control is on one screen, making it intuitive and easy to understand. New setup menus offer more controls than ever for owners and managers to optimize the machine for their business needs. For the sprayer/operator - the single home-screen is sufficient to operate the machine. Extra features and advanced settings can be password protected for crews and operators.

Independent Hose Temperature

- Hose temperatures will follow the A and B material set points to help optimize your spray pattern and maximize material yield

Inlet Material Intelligence

- Quickly see temperature, pressure and volume of A and B material remaining

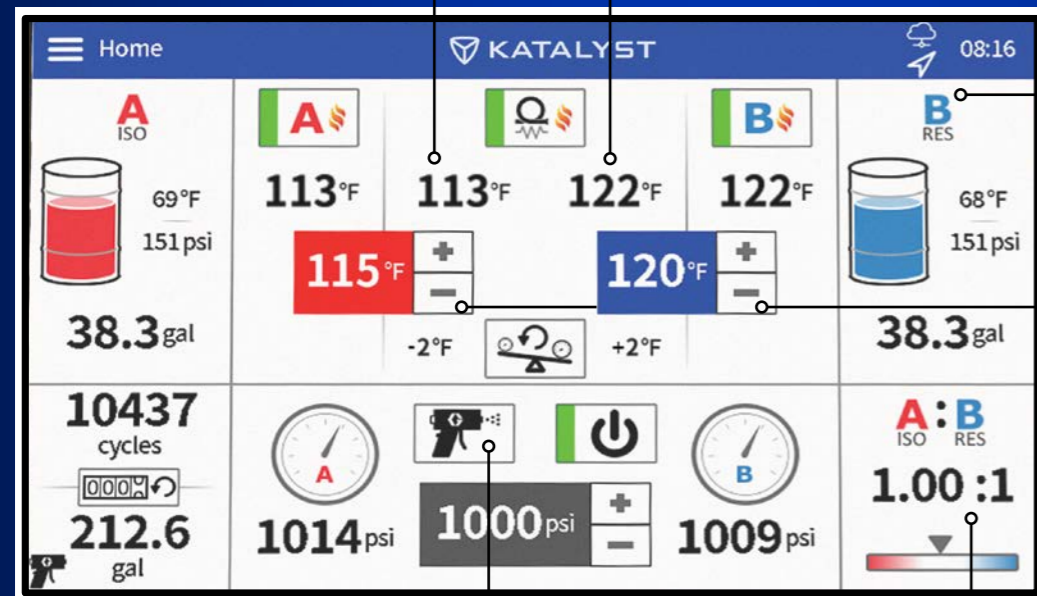

A and B Fluid Temperature Set Points

- Simplified operations with only two temperature set points
- With independently heated hoses, the A and B materials are heated to your exact A and B temperature setpoints

System Modes

- Quickly change between Spray, Jog and Park modes with the touch of a button

Ratio Assurance

- When equipped with flow meters, view real-time ratio performance

* Picture shown represents an Elite model.

REACTOR CONNECT

Remote Monitoring is Always Within Reach

Reactor Connect is designed for both Sprayers and Owners/Managers alike. Use Reactor Connect to track ratios, receive alerts and view data directly from your smartphone. As a result, owners/managers can monitor rigs, access reports, troubleshoot issues from anywhere and get the crew back to work quickly.

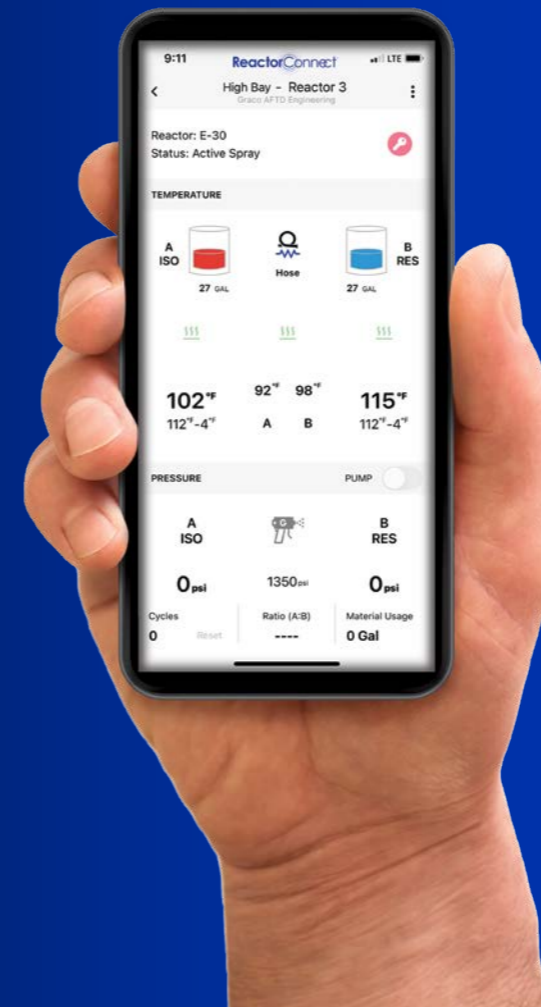

REACTOR CONTROL SCREEN - Reactor Connect App

- Adjust temperature and pressure points
- View drum levels
- Turn heat zones on/off
- View and reset cycle counter/material usage
- Turn system on/off
- Turn pump on/off
- Toggle between Spray, Park and Jog modes
- View ratio

MULTI-SYSTEM DASHBOARD - Reactor Connect App

- Current Reactor status
- Daily "power on" time
- Actual "spray" time
- Daily material usage

ONLINE INTERFACE - Reactor Connect Website

- Create user accounts, company profiles and users
- Assign Reactors to your accounts
- Advanced Reactor analytics
- Control access
- GPS location maps
- Automated summary reports
- Customized reporting

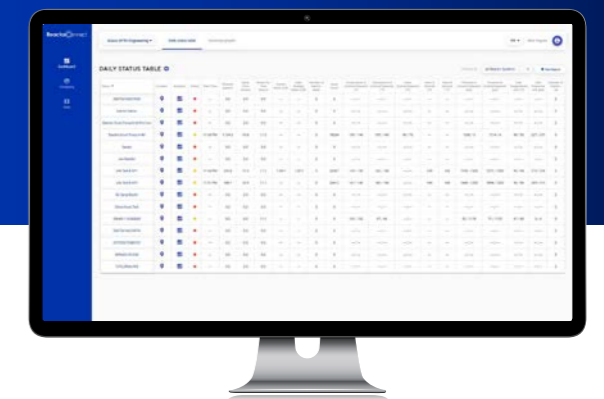

GRACO EXPERTS BY YOUR SIDE

Experienced graco technicians can access your Reactor system and troubleshoot issues for you remotely

ADD YOUR DISTRIBUTOR FOR FURTHER HELP

Reactor Analytics is a great tool for analyzing machine performance and quickly diagnosing possible issues. Add your Graco equipment distributor to your Reactor Connect company so they can offer assistance.

KATALYST CONTROL FOR REACTOR 3

Eliminates the Largest Causes of Off-Ratio Issues

Katalyst, the new Reactor 3 software, provides the highest level system intelligence to optimize spray, eliminate ratio issues, improve yield, to help deliver quality results every time.



HOW TO ACTIVATE KATALYST: Set-up is Simple

- 1 Install Core E1 transfer pumps on your new Reactor 3 Elite proportioner
- 2 Turn on the machine and acknowledge "Electric Transfer Pumps" when prompted. That's it...your Katalyst software is enabled

ACTIVATE KATALYST FOR TOTAL SYSTEM INTELLIGENCE

Katalyst software ensures your system is operating utilizing the most advanced hardware and software features available, allowing even first-time sprayers to achieve professional quality results.

KATALYST PROVIDES FULL COMMUNICATION AND CONTROL

- Communication with the Core E1 pumps nearly eliminates two of the largest causes of off-ratio spraying
 - **Air in the fluid stream:** With Katalyst the system will automatically shut you down when run out of material so air does not enter into the fluid stream
 - **Improperly feeding the Reactor with material:** Katalyst automatically adjusts power to the pumps to always provide optimal material feed to the Reactor. e.g., helping to eliminate feed issues with cold materials
- Communication with Xcelerator heated hoses allows for full independent A and B hose heat adjustments and the option of automatic pressure balancing for improved yield



IMPROVE YOUR MATERIAL YIELD USING KATALYST

Even a 5% yield improvement can mean big savings for your business. Calculate your own savings using the calculator below:

MATERIAL COST PER SET	\$3,000
SETS PER YEAR	250
EST. YIELD IMPROVEMENT	5%
ANNUAL SAVINGS: (Cost/set) x (Sets/year) x (Yield Improvement)	\$37,500

* Individual yield improvement may vary.

* Standard and Pro models can upgrade hardware to activate Katalyst System Intelligence.

CORE E1 ELECTRIC TRANSFER PUMPS

Powerful, Quiet, Smart

Get in the flow with Graco's revolutionary NEW Core electric transfer pumps; designed to optimize material supply and minimize downtime. Quieter and less expensive to operate than traditional pneumatic pumps, the new all-electric pumps can communicate with the Reactor 3 to give you a fully connected system. At the same time, reducing the air consumption in your spray rig with electric feed pumps, will allow an owner to downsize the compressor. Which will reduce the weight, footprint and maintenance cost.



NEW SUPPLY PUMP SHUTDOWN

Senses when a drum is empty and automatically shuts down the transfer pumps and Reactor 3 proportioner before damage occurs, including air entering the system and that can compromise ratio.

NEW SMART SUPPLY

The software automatically monitors and adjusts Reactor 3 proportioner inlet pressures to optimize material feed and on-ratio performance. Maintains inlet pressure between 5,5 - 14 bar — boosting power to the transfer pump's electric motors when needed. Achieve Smart Supply when using Core E1 pumps with a Reactor 3 Elite model.



With our exclusive ProConnect technology, you can quickly disconnect the motor from the pump lower and easily transfer the pump from drum to drum.... even in low ceiling height rigs. No more having to pay more for taller rigs or having to tip the drum in order to remove the pump.

TIP: Have an extra pump lower installed on your rig to make changing drums even faster and cleaner.



CONNECTIONS MADE EASY!

Connecting your motor to the lower just got as easy as 1, 2, 3.

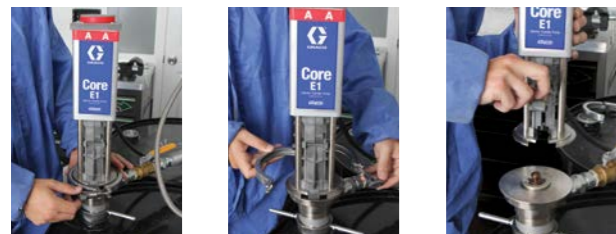

1. Loosen T-handle 2. Open Pump Clamp 3. Slide Electric Motor to Remove

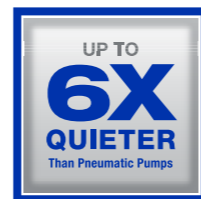

That's equivalent to reducing the sound in your rig from being as loud as a motorcycle to that of a car.

XCELERATOR HEATED HOSES

Faster to Heat, Lighter Weight, Improved Flexibility

Graco's new Xcelerator heated hoses gives you more options and control than ever. All Xcelerator hoses are designed to provide full independent A and B temperature control. This provides more precise pressure balancing and improved material yield. New robust construction provides longer life and reduced maintenance.



HOSE CONNECTIONS THAT ARE LIGHTWEIGHT AND ROBUST

Graco's new electrical connectors are designed with the user in mind

- 1 **Pin and Socket Connectors**
 - Male/Female connectors provide a strong, reliable electric connection
- 2 **Gasket and O-Ring Seal**
 - Provides moisture proof electrical connection
- 3 **Keyed Feature**
 - Different keys on A and B connectors prevent incorrect connections

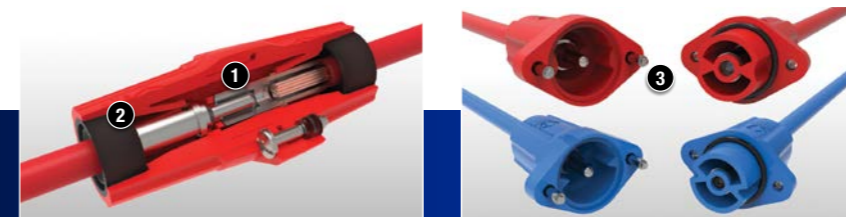

DESIGNED FOR SPEED AND RELIABILITY

- Fully independent A and B temperature control
- Internally & externally heated options
- Available in 15m and 30m lengths: Minimizes fluid and electrical connections
- Optimized for Resistance Control Mode: Reduces maintenance and issues with no cables or FTS sensors required

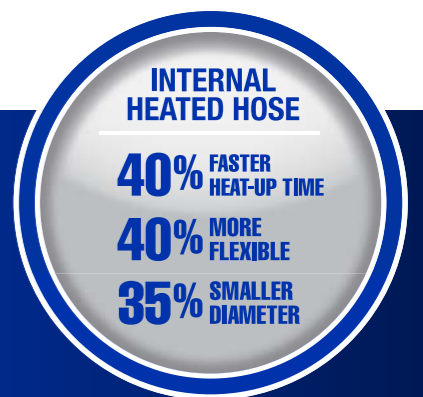

GRACO'S NEW INTERNAL HEATED HOSE HAS THE SMALLEST, LIGHTEST WEIGHT CONNECTIONS IN THE INDUSTRY

The robust, compact design allows the heating element to enter/exit the fluid stream at each hose joint without adding significant size or weight.

- 1 **Heating Wire**
 - Heating wire is located in hose ID for direct material contact and quick heating
- 2 **Wire Seal Nut/Ferrule/O-ring/Bushing**
 - These components allow the heating wire to transition out of fluid and provide a proper seal
- 3 **Crimp Connector**
 - Connects the heating wire to the multi strand wire that allows the hose power to connect between hose joints

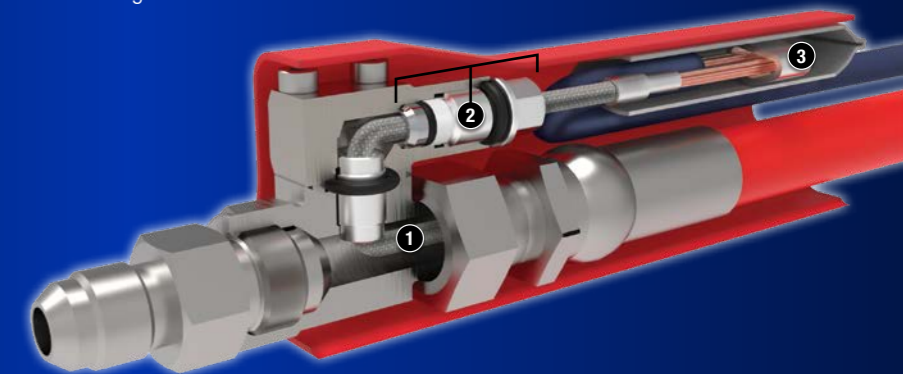

SPRAY FOAM PROPORTIONERS

POLYUREA PROPORTIONERS

Standard – Spray Foam Proportioners & Packages



ESR310 Shown

REACTOR 3 E-20

- 26R310 Reactor 3, E-20, Standard, 7kW Heat**
- ESR310 Package: 15m ext heated hose, 3m whip
- EHR310 Package: 15m ext heated hose (qty 4), 3m whip
- ISR310 Package: 15m int heated hose, 6m whip
- IHR310 Package: 30m int heated hose (qty 2), 6m whip

REACTOR 3 E-30

- 26R330 Reactor 3, E-30, Standard, 10kW Heat**
- ESR330 Package: 15m ext heated hose, 3m whip
- EHR330 Package: 15m ext heated hose (qty 4), 3m whip
- ISR330 Package: 15m int heated hose, 6m whip
- IHR330 Package: 30m int heated hose (qty 2), 6m whip

Standard – Polyurea Proportioners & Packages



ESR320 Shown

REACTOR 3 E-XP1

- 26R320 Reactor 3, E-XP1, Standard, 10kW Heat**
- ESR320 Package: 15m ext heated hose, 3m whip
- EHR320 Package: 15m ext heated hose (qty 4), 3m whip
- ISR320 Package: 15m int heated hose, 6m whip
- IHR320 Package: 30m int heated hose (qty 2), 6m whip

REACTOR 3 E-XP2

- 26R340 Reactor 3, E-XP2, Standard, 15kW Heat**
- ESR340 Package: 15m ext heated hose, 3m whip
- EHR340 Package: 15m ext heated hose (qty 4), 3m whip
- ISR340 Package: 15m int heated hose, 6m whip
- IHR340 Package: 30m int heated hose (qty 2), 6m whip

Pro – Spray Foam Proportioners & Packages



ESR311 Shown

REACTOR 3 E-20

- 26R311 Reactor 3, E-20, Pro, 7kW Heat**
- ESR311 Package: 15m ext heated hose, 3m whip
- EHR311 Package: 15m ext heated hose (qty 4), 3m whip
- ISR311 Package: 15m int heated hose, 6m whip
- IHR311 Package: 30m int heated hose (qty 2), 6m whip

REACTOR 3 E-30

- 26R331 Reactor 3, E-30, Pro, 10kW Heat**
- ESR331 Package: 15m ext heated hose, 3m whip
- EHR331 Package: 15m ext heated hose (qty 4), 3m whip
- ISR331 Package: 15m int heated hose, 6m whip
- IHR331 Package: 30m int heated hose (qty 2), 6m whip

26R313 Reactor 3, E-20, Pro, 10kW Heat

- ESR313 Package: 15m ext heated hose, 3m whip
- EHR313 Package: 15m ext heated hose (qty 4), 3m whip
- ISR313 Package: 15m int heated hose, 6m whip
- IHR313 Package: 30m int heated hose (qty 2), 6m whip

26R333 Reactor 3, E-30, Pro, 15kW Heat

- ESR333 Package: 15m ext heated hose, 3m whip
- EHR333 Package: 15m ext heated hose (qty 4), 3m whip
- ISR333 Package: 15m int heated hose, 6m whip
- IHR333 Package: 30m int heated hose (qty 2), 6m whip

Pro – Polyurea Proportioners & Packages



ESR321 Shown

REACTOR 3 E-XP1

- 26R321 Reactor 3, E-XP1, Pro, 10kW Heat**
- ESR321 Package: 15m ext heated hose, 13m whip
- EHR321 Package: 15m ext heated hose (qty 4), 3m whip
- ISR321 Package: 15m int heated hose, 6m whip
- IHR321 Package: 30m int heated hose (qty 2), 6m whip

REACTOR 3 E-XP2

- 26R341 Reactor 3, E-XP2, Pro, 15kW Heat**
- ESR341 Package: 15m ext heated hose, 3m whip
- EHR341 Package: 15m ext heated hose (qty 4), 3m whip
- ISR341 Package: 15m int heated hose, 6m whip
- IHR341 Package: 30m int heated hose (qty 2), 6m whip

Elite – Spray Foam Proportioners & Packages



ISR312 Shown

REACTOR 3 E-20

- 26R312 Reactor 3, E-20, Elite, 10kW Heat**
- ESR312 Package: 15m ext heated hose, 6m whip, engine cable
- EHR312 Package: 15m ext heated hose (qty 4), 6m whip, engine cable
- ISR312 Package: 15m int heated hose, 6m whip, engine cable
- IHR312 Package: 30m int heated hose (qty 2), 6m whip, engine cable

REACTOR 3 E-30

- 26R332 Reactor 3, E-30, Elite, 15kW Heat**
- ESR332 Package: 15m ext heated hose, 6m whip, engine cable
- EHR332 Package: 15m ext heated hose (qty 4), 6m whip, engine cable
- ISR332 Package: 15m int heated hose, 6m whip, engine cable
- IHR332 Package: 30m int heated hose (qty 2), 6m whip, engine cable

Elite – Polyurea Proportioners & Packages



ISR322 Shown

REACTOR 3 E-XP1

- 26R322 Reactor 3, E-XP1, Elite, 10kW Heat**
- ESR322 Package: 15m ext heated hose, 6m whip, engine cable
- EHR322 Package: 15m ext heated hose (qty 4), 6m whip, engine cable
- ISR322 Package: 15m int heated hose, 6m whip, engine cable
- IHR322 Package: 30m int heated hose (qty 2), 6m whip, engine cable

REACTOR 3 E-XP2

- 26R342 Reactor 3, E-XP2, Elite, 15kW Heat**
- ESR342 Package: 15m ext heated hose, 6m whip, engine cable
- EHR342 Package: 15m ext heated hose (qty 4), 6m whip, engine cable
- ISR342 Package: 15m int heated hose, 6m whip, engine cable
- IHR342 Package: 30m int heated hose (qty 2), 6m whip, engine cable

Complete Elite Packages:

Complete packages include Reactor Elite proportioner, Internally Heated Hoses and Core E1 Pumps

REACTOR 3 E-20

- CSR312 Package: Reactor E-20 Elite, 15m int heated hose, 6m whip, engine cable, Core E1 pump kit
- CHR312 Package: Reactor E-20 Elite, 30m int heated hose (qty 2), 6m whip, engine cable, Core E1 pump kit

REACTOR 3 E-30

- CSR332 Package: Reactor E-30 Elite, 15m int heated hose, 6m whip, engine cable, Core E1 pump kit
- CHR332 Package: Reactor E-30 Elite, 30m int heated hose (qty 2), 6m whip, engine cable, Core E1 pump kit

Complete Elite Packages:

Complete packages include Reactor Elite proportioner, Internally Heated Hoses and Core E1 Pumps

REACTOR 3 E-XP1

- CSR322 Package: Reactor E-XP1 Elite, 15m int heated hose, 6m whip, engine cable, Core E1 pump kit
- CHR322 Package: Reactor E-XP1 Elite, 30m int heated hose (qty 2), 6m whip, engine cable, Core E1 pump kit

REACTOR 3 E-XP2

- CSR342 Package: Reactor E-XP2 Elite, 15m int heated hose, 6m whip, engine cable, Core E1 pump kit
- CHR342 Package: Reactor E-XP2 Elite, 30m int heated hose (qty 2), 6m whip, engine cable, Core E1 pump kit



DON'T FORGET TO CHOOSE YOUR GUN SEPARATELY WHEN ORDERING YOUR REACTOR

Fusion® PC Gun – A Perfect Rebuild in Seconds

For more information on additional gun options, see P&A brochure

REACTOR 3 HOSES



HOSE – SPRAY FOAM

- 25P775 **Whip:** 6.35 mm I.D. (1/4 in.), 3m, LP, 140 bar
- 25P776 **Whip:** 6.35 mm I.D. (1/4 in.), 6m, LP, 140 bar

- 96B101 **Hose:** 9.5 mm I.D. (3/8 in.), Externally heated, LP, 140 bar, 15m, Blue Mesh
- 96B125 **Hose:** 9.5 mm I.D. (3/8 in.), Externally heated, LP, 140 bar, 15m, Blue Mesh, RTD

- 25P434 **Hose:** 9.5 mm I.D. (3/8 in.), Internally heated, LP, 140 bar, 15m, Xtreme-Wrap™
- 25P435 **Hose:** 9.5 mm I.D. (3/8 in.), Internally heated, LP, 140 bar, 30m, Xtreme-Wrap™
- 25P437 **Hose:** 9.5 mm I.D. (3/8 in.), Internally heated, LP, 140 bar, 15m, Xtreme-Wrap™, RTD
- 25P438 **Hose:** 9.5 mm I.D. (3/8 in.), Internally heated, LP, 140 bar, 30m, Xtreme-Wrap™, RTD



HOSE – POLYUREA

- 25P777 **Whip:** 6.35 mm I.D. (1/4 in.), 3m, HP, 240 bar
- 25P778 **Whip:** 6.35 mm I.D. (1/4 in.), 6m, HP, 240 bar

- 96B111 **Hose:** 9.5 mm I.D. (3/8 in.), Externally heated, HP, 240 bar, 15m, Blue Mesh
- 96B145 **Hose:** 9.5 mm I.D. (3/8 in.), Externally heated, HP, 240 bar, 15m, Blue Mesh, RTD

- 25P534 **Hose:** 9.5 mm I.D. (3/8 in.), Internally heated, HP, 240 bar, 15m, Xtreme-Wrap™
- 25P535 **Hose:** 9.5 mm I.D. (3/8 in.), Internally heated, HP, 240 bar, 30m, Xtreme-Wrap™
- 25P537 **Hose:** 9.5 mm I.D. (3/8 in.), Internally heated, HP, 240 bar, 15m, Xtreme-Wrap™, RTD
- 25P538 **Hose:** 9.5 mm I.D. (3/8 in.), Internally heated, HP, 240 bar, 30m, Xtreme-Wrap™, RTD

HOSE ACCESSORIES

- 18E175 **Dual FTS Kit** for Independedntly Heated Hoses
- 18E176 **Xcelerator Xtreme Wrap** 15m
- 18E177 **Xcelerator Xtreme Wrap** 30m

REACTOR 3 ACCESSORIES



CORE E1 TRANSFER PUMPS

- 26D004 **E1** Transfer Pump
- 26D005 **E1 PKG:** two pumps, Transfer Pump Controller, CAN cable
- 26D006 **E1 PKG:** two pumps, Transfer Pump Controller, CAN cable, fluid hoses
- 26D277 **E1 PKG:** two pumps, Transfer Pump Controller, CAN cable, fluid and air hoses
- 26D000 **TPC:** Transfer Pump Controller (TPC), Core E1, kit w. Cables
- 273295 **T4/E1:** Pump Lower, Carbon Steel, (Bung adapter not included)



T4 TRANSFER PUMPS

- 26D001 **T4 Pump**
- 26D002 **T4 PKG:** two pumps, fluid hoses
- 26D003 **T4 PKG:** two pumps, fluid and air hoses
- 273295 **T4/E1:** Pump Lower, Carbon Steel, (Bung adapter not included)
- 25B395 **Kit:** Bung Adapter, 2 in, EZ Removal



KITS TO UPGRADE STANDARD AND PRO MODELS

- 18E212 **Kit:** Reactor 3, Ratio Assurance
- 18E246 **Kit:** Strainer, Reactor 3, Pair, Pro
- 18E247 **Kit:** Strainer, Reactor 3, Pair, Elite
- 18E248 **Kit:** Sensors, Inlet, Temperature, Pressure
- 255148 **Kit:** Large Recirculation Valve Set



REACTOR CONNECT KITS

- 18E244 **Reactor Connect Kit:** Var. Countries, CAT-M, GPS
- 18E243 **Reactor Connect Kit:** Var. Countries, 3G, GSM, GPS
- 18E211 **Kit:** R3, Remote Mount Bracket

ACCESSORY KITS

- 18E154 **Kit:** Reactor 3, Air Manifold
- 20A677 **Kit:** Reactor 3, Engine CAN, Harness
- 20A676 **Kit:** Reactor 3, Light Tower
- 18D314PKG **ADM:** Touchscreen screen protectors, 10 pack
- 25T859 **Kit:** TSL, bottle, (1 qt)
- 24M174 **Kit:** Drum level dip sticks



ADD CORE E1 TRANSFER PUMPS TO ANY REACTOR 3

A Complete System Fully Connected From Drum-to-Gun

For more information on Transfer Pump options, see P&A brochure



ABOUT GRACO

Founded in 1926, Graco is a world leader in fluid handling systems and components. Graco products move, measure, control, dispense and apply a wide range of fluids and viscous materials used in vehicle lubrication, commercial and industrial settings.

The company's success is based on its unwavering commitment to technical excellence, world-class manufacturing and unparalleled customer service. Working closely with qualified distributors, Graco offers systems, products and technology that set the quality standard in a wide range of fluid handling solutions. Graco provides equipment for spray finishing, protective coating, paint circulation, lubrication, and dispensing sealants and adhesives, along with power application equipment for the contractor industry. Graco's ongoing investment in fluid management and control will continue to provide innovative solutions to a diverse global market.

ABOUT AEMCO

AEMCO was established in 2007 as an organization focused to increase professionalism and productivity in the arena of coating and surface preparation across the Kingdom of Saudi Arabia. Latest trends and technologies in coating industry were made available from AEMCO to our professional end users to achieve quality results and satisfaction. We started our operations in Riyadh and expanded to Central, Eastern, Western and Northern Region of the Kingdom.

نبذة عن الشركة:

تأسست شركة إيمكو في عام ٢٠٠٧ لتكون شركة تركز على زيادة الاحترافية والإنتاجية في ميدان الطلاء وتجهيز الأسطح للدهان في المملكة العربية السعودية. وفرت شركة إيمكو أحدث أساليب التقنية في مجال تنفيذ الطلاء لعملائنا المحترفين في صناعة تنفيذ الطلاء للوصول الى نتائج مبهرة ومرضية. بدأنا عملياتنا في الرياض وتطورت لتصل الى المنطقة الوسطى، المنطقة الشرقية، المنطقة الغربية والمنطقة الشمالية من المملكة العربية السعودية.

AEMCO LOCATIONS

RIYADH	DAMMAM	JEDDAH
Second Ring Road, Near Morni, As Sulay, Riyadh:14285, KSA Tel: +966 11 2140888	King Abdul Aziz Road, Opp.DHL Head Office, Thuqba Area , Al-Khobar KSA. Tel: +966 13 8021334	Prince Abdul Majeed Road, North Obhur. Al Shera'a District, Jeddah: 23814, KSA Tel: +966 11 2637048

All written and visual data contained in this document is based on the latest product information available at the time of publication. Graco reserves the right to make changes at any time without notice.

AEMCO

+966 -11- 21 40 888
marketing@aemco-llc.com
www.aemco-llc.com

جده الدمام الرياض
Riyadh Damman Jeddah



Genuine People
Genuine Spares
Genuine Service