

LWSE 1601

ELECTRIC WALL SAW FOR UNIVERSAL APPLICATIONS AND EVERYDAY USE ON THE CONSTRUCTION SITE

- For universal usage and the daily use on the construction site
- Modular usable, compact and light components
- Newly designed, ultra-light and stable blade guard
- Compact drive motor with tool-free motor fastening
- Handy remote control with colour display
- Innovative communication interfaces
- Revolutionary drive technology for outstanding reliability without loss of performance

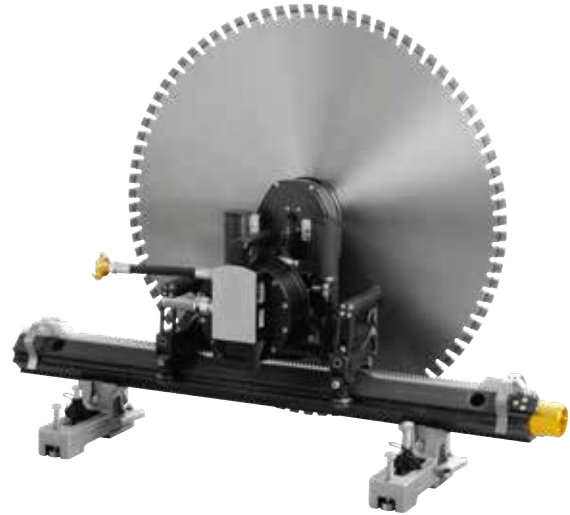

TECHNICAL DATA	LWSE 1601
cutting depth max.	705 mm
saw blade Ø max.	1600 mm
free detachable up to Ø	900 mm
arbor size	60 mm
blade flange mounting	quick-release flange
saw blade fixing (flush cuts)	6 countersunk head screws, TK 130 mm
motor	water-cooled, without gearbox
output power	20 kW (32 A) / S1/17 kW/ (32 A)
voltage	400- 480 V
frequency	50 Hz / 60 Hz
protection class	IP 67
weight sawing body	23,5 kg
weight drive	15 kg



[1] Electric control unit+ radio remote control [2] V-Track feet alu

[3] Blade guard

WALL SAW SYSTEM LWSE 1601	NR.
LWSE 1601 wall saw incl. feed motors	1092268
LWSE 1601 - electric main drive motor 400 V/50 Hz	1092269
[1] LWSE 1601 - electric control unit 400 V/50 Hz	1092270
LWSE 1601 - VAS G Track / 1100 mm / alu	1042090
LWSE 1601 - VAS G Track / 2200 mm / alu	1042088
LWSE 1601 - track connector for VAS and VS tracks	1042075
[2] LWSE 1601 - V-Track feet alu, flat (recommended: 3 pieces)	1042045
[3] LWSE 1601 - blade guard 1000 mm, All-In-One	1092271
LWSE 1601 - tool box	1092272
LWSE 1601 - transport trolley	1092273
ACCESSORIES	NR.
[3] LWSE 1601 - blade guard 800 mm, All-In-One	1092274
[3] LWSE 1601 - blade guard 1200 mm, All-In-One	1092275
LWSE 1601 - blade guard 1600 mm 2 parts	1092276
LWSE 1601 - blade guard uptake 1600 mm	1092277
LWSE 1601 - V-swivel track feet	1092278
LWSE 1601 - V-rotary rail support compl.	1092279

